

E-18 & 24 STAND ASSEMBLY

ASSEMBLING INSTRUCTIONS

(If a shelf is desired, now is the time to cut a piece of 3/4" plywood to the dimensions indicated in the drawing.) Assemble stand referring to diagram and pictures. Pay close attention to Detail A that shows the upper joint configuration, and Detail B that shows the lower joint configuration. The stand is now assembled. You are ready to bolt the press to the top of the stand using the 5/16-18 x 1-1/2 HEX bolts provided, bolt thru the pre-punched holes in the top side rails.

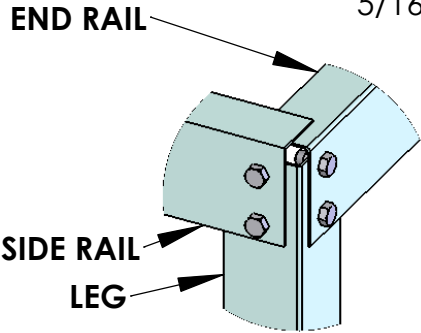

DETAIL A
BLOWN UP VIEW
OF TOP JOINT
(SIDE RAIL BOLTS ON OUTSIDE
OF LEG **OVER-LAPPING** END RAIL.
END RAIL BOLTS ON OUTSIDE OF
LEG **UNDER-LAPPING** SIDE RAIL.)

- (32) 3/8-16 x 5/8
- (32) 3/8 LOCK WASHERS
- (32) 3/8-16 NUTS

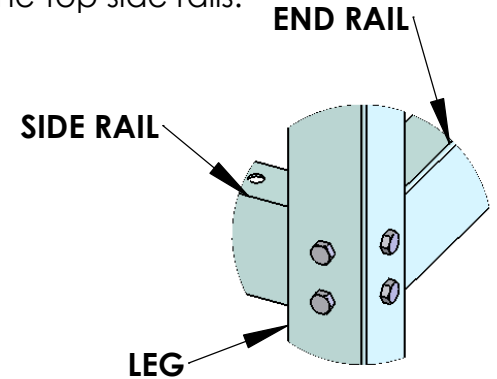

DETAIL B
BLOWN UP VIEW
OF LOWER JOINT
(SIDE RAIL BOLTS ON INSIDE
OF LEG **OVER-LAPPING** END RAIL.
END RAIL BOLTS ON INSIDE OF
LEG **UNDER-LAPPING** SIDE RAIL.)

**ONLY IF STAND GETS
CASTER (4) 23.5" LEGS**

OPTIONAL: (4) CASTERS

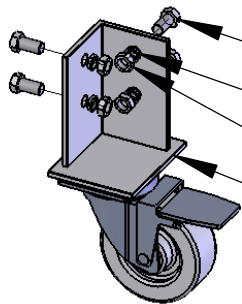

- (16) 3/8-16 x 7/8
- (16) 3/8 LOCK WASHERS
- (16) 3/8-16 NUT
- (4) CASTERS

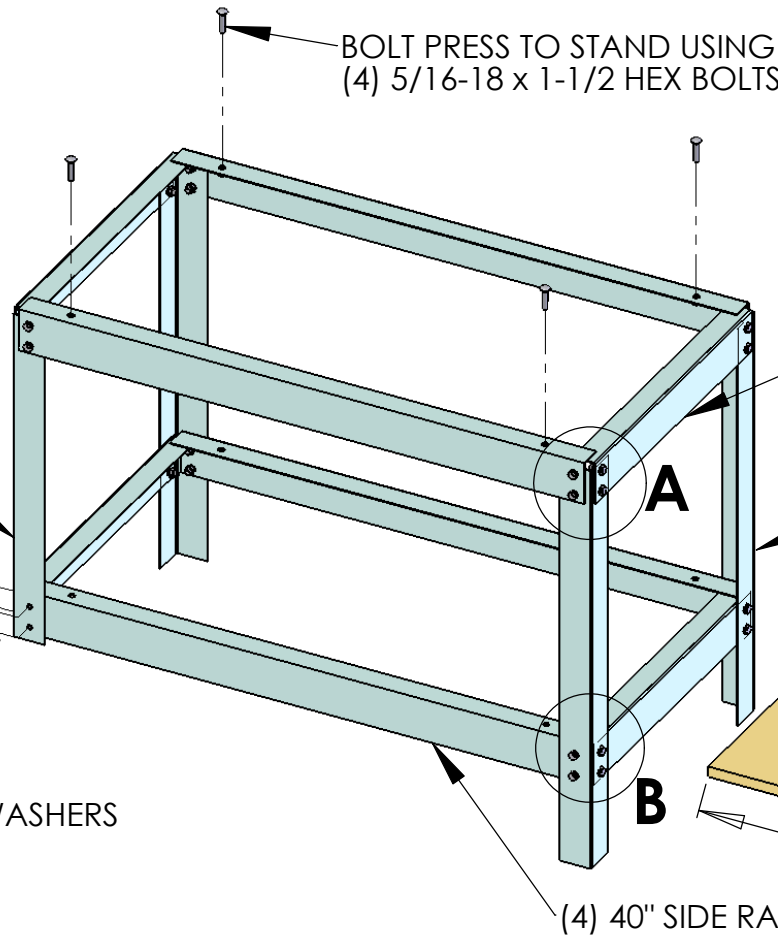

E-18 uses (4) 21" end rails
E-24 uses (4) 27" end rails

**ONLY STANDS WITH OUT
CASTERS (4) 29" LEGS**

