

E-12 & 15 ASSEMBLY

ASSEMBLING INSTRUCTIONS

When using this stand for E-12 or E-15 presses you must provide a piece of 3/4" plywood for the top. **Cut 3/4" plywood for the top to 23" x 42"** (If a shelf is desired, now is the time to cut and fit plywood shelf to dimensions indicated in diagram.) Assemble stand referring to diagram and pictures. Pay close attention to Detail A that shows the upper joint configuration, and Detail B that shows the lower joint configuration. Bolt plywood to top of stand with carriage bolts provided. The press can now be located on the plywood top so the handle or star wheel will clear the side of the stand. Bolt the press to the plywood with #10 wood screws provided.

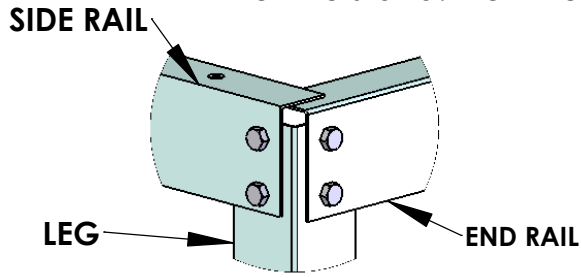

DETAIL A
BLOWN UP VIEW
OF TOP JOINT
(SIDE RAIL BOLTS ON OUTSIDE OF LEG **OVER-LAPPING** END RAIL. END RAIL BOLTS ON OUTSIDE OF LEG **UNDER-LAPPING** SIDE RAIL.)

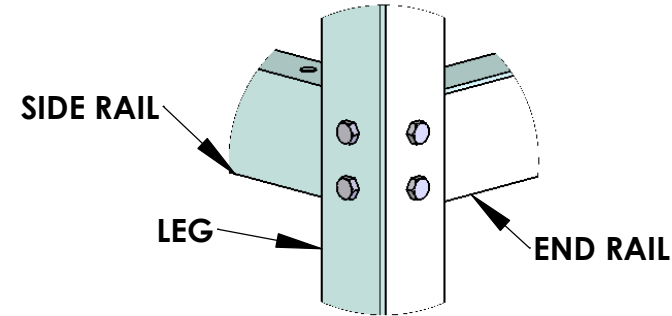
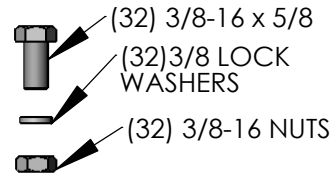

DETAIL B
BLOWN UP VIEW
OF LOWER JOINT
(SIDE RAIL BOLTS ON INSIDE OF LEG **OVER-LAPPING** END RAIL. END RAIL BOLTS ON INSIDE OF LEG **UNDER-LAPPING** SIDE RAIL.)

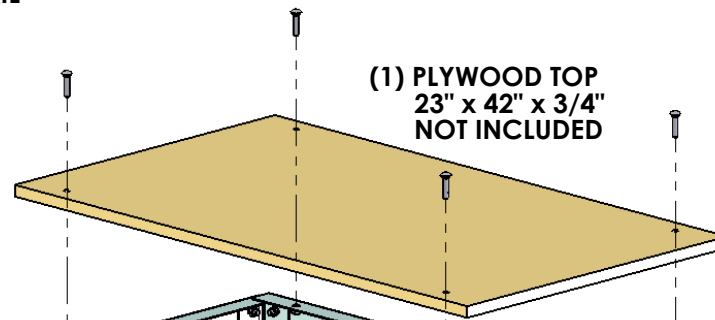

ONLY IF STAND GETS CASTER (4) 23.5" LEGS

OPTIONAL: (4) CASTERS

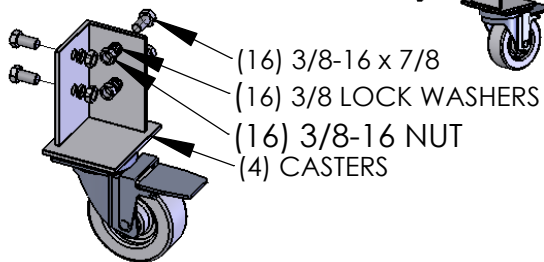

(4) END RAILS

ONLY STANDS WITH OUT CASTERS (4) 29" LEGS

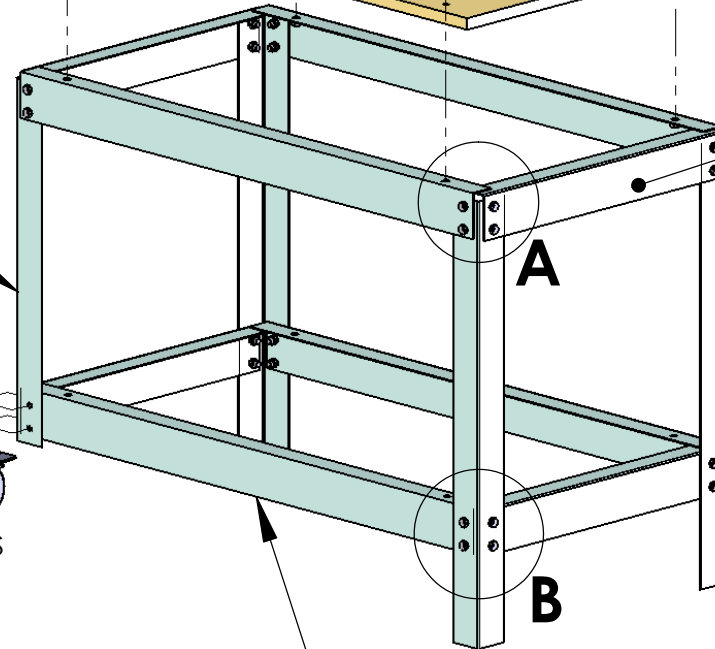

(4) 40" SIDE RAILS

(1) PLYWOOD SHELF
 $21\frac{1}{2}" \times 40\frac{1}{2}" \times \frac{3}{4}"$
NOT INCLUDED

