

C-25 & C-24 COMBO STAND

ASSEMBLING INSTRUCTIONS

It is suggested to assemble the stand upside down, so you can start with the upper side rails and upper end rails flat on the ground. Lay out all the parts, find the upper front and rear side rails, the top holes on these two parts should be offset to the right. Find the right and left upper end rails, the top holes on these two parts should be offset closest to the front side rails. Refer to the diagram and pictures, Pay close attention to Detail A that shows the upper joint configuration, and Detail B that shows the lower joint configuration. Assemble all parts with very little tension on the bolts so stand may be squared before final tightening of the bolts. Square the legs to the side and end rails, then tighten bolts. The stand is now assembled. You are ready to bolt the press to the top of the stand using the 5/16-18 x 1-1/2 HEX bolts provided, bolt press to stand using the pre-punched holes in the top side rails. Bolt outriggers to stand, use the pre-punched holes in the end rails.

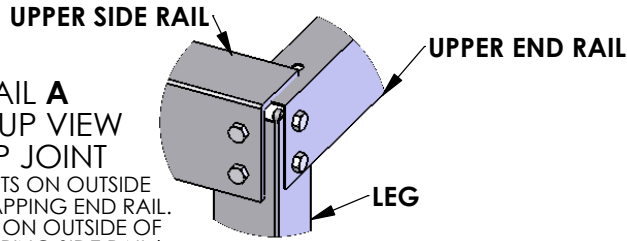

DETAIL A
BLOWN UP VIEW
OF TOP JOINT

(SIDE RAIL BOLTS ON OUTSIDE OF LEG **OVER-LAPPING** END RAIL. END RAIL BOLTS ON OUTSIDE OF LEG **UNDER-LAPPING** SIDE RAIL.)

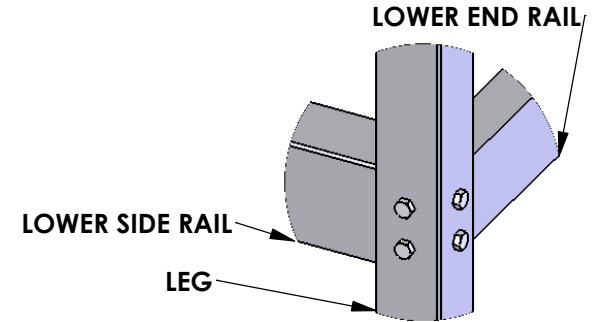
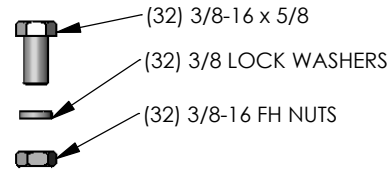

DETAIL B
BLOWN UP VIEW
OF LOWER JOINT
(SIDE RAIL BOLTS ON INSIDE OF LEG **OVER-LAPPING** END RAIL. END RAIL BOLTS ON INSIDE OF LEG **UNDER-LAPPING** SIDE RAIL.)

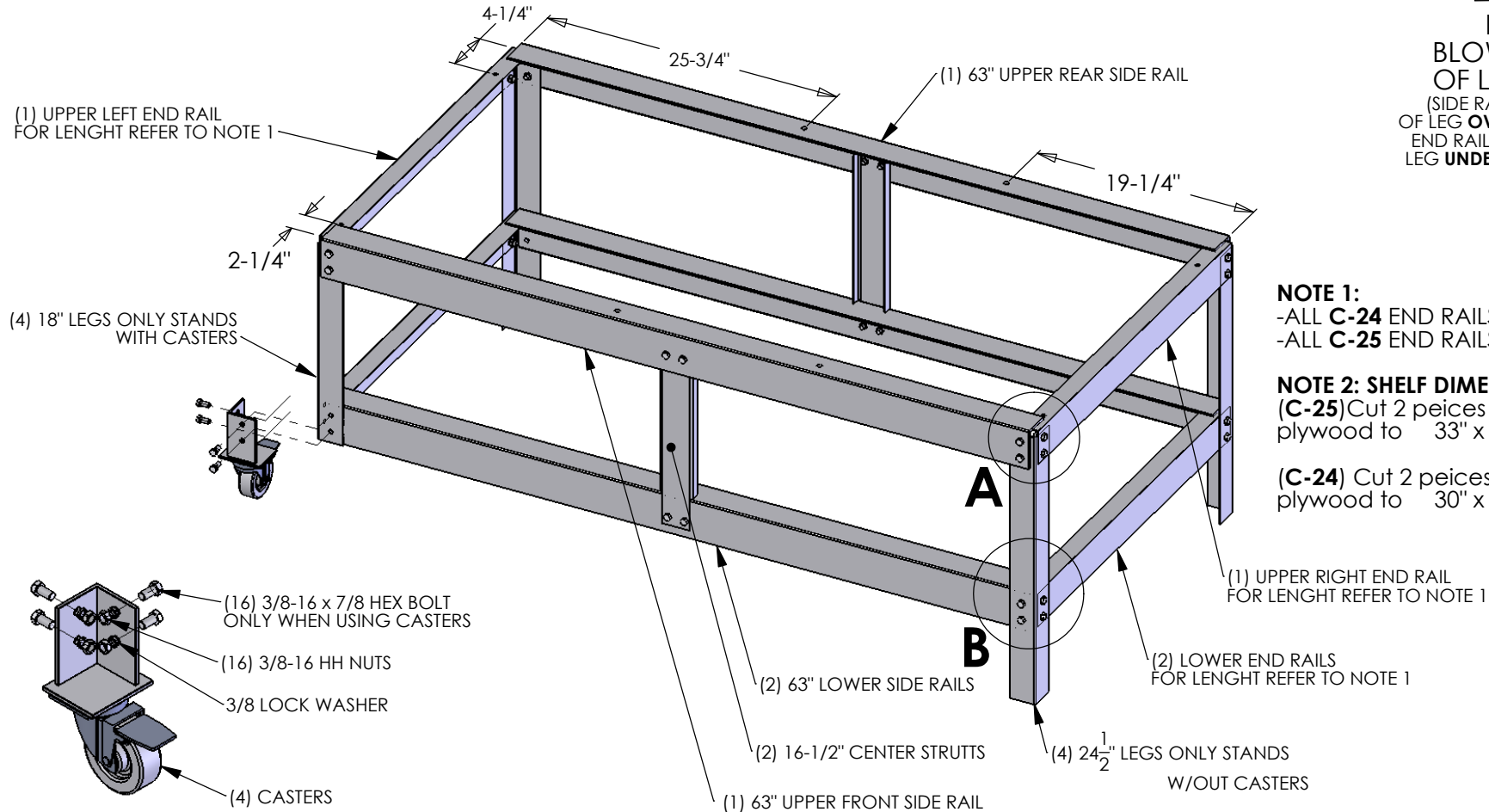

NOTE 1:
-ALL **C-24** END RAILS ARE 29-1/2" LONG
-ALL **C-25** END RAILS ARE 32-1/2" LONG

NOTE 2: SHELF DIMENSIONS
(**C-25**) Cut 2 pieces of 1/2" plywood to 33" x 31-3/4"
(**C-24**) Cut 2 pieces of 1/2" plywood to 30" x 31-3/4"

