

C-16 STAND

ASSEMBLY INSTRUCTIONS

When using this stand for a C16 combination press, you must provide a piece of 3/4" plywood for the top. If a shelf is desired you must cut a piece of 3/4" plywood to the given dimensions and insert during assembly. Bolt plywood top to the top of the stand in the 4 corners using the (4) 5/16" x 1-1/2" carriage bolts provided. Center press on the top of the stand. Using a hand drill with a 5/16 drill bit drill the plywood thru the bolt down holes in the base of the press. Use the (4) 5/16 X 1-1/2" hex bolts to bolt the press to the stand.

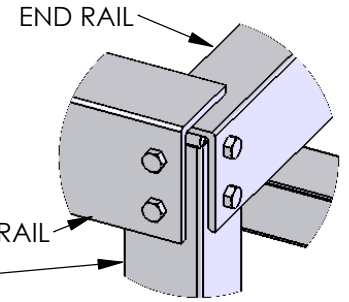

DETAIL A
BLOWN UP VIEW
OF TOP JOINT
 (SIDE RAIL BOLTS ON OUTSIDE OF LEG **OVER-LAPPING** END RAIL. END RAIL BOLTS ON OUTSIDE OF LEG **UNDER-LAPPING** SIDE RAIL.)

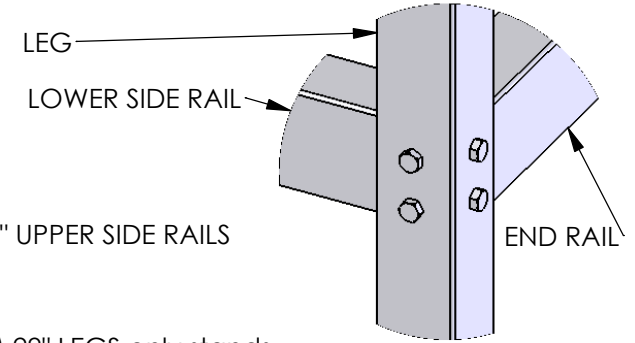

DETAIL B
BLOWN UP VIEW
OF LOWER JOINT
 (SIDE RAIL BOLTS ON INSIDE OF LEG **OVER-LAPPING** END RAIL. END RAIL BOLTS ON INSIDE OF LEG **UNDER-LAPPING** SIDE RAIL.)

